

Read the notes!

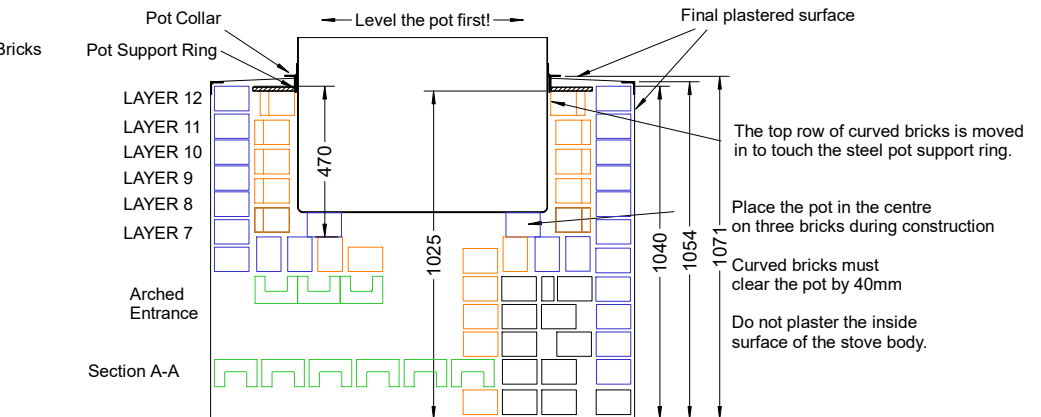

Note 1

The plaster thickness is assumed to be 15mm. Therefore the outside dimensions of the stove body will be $1300+30 = 1330$ mm wide.

The height will be $1040 + 15 = 1055$ mm.

The overall height of the brickwork is not critical as the collar can be moved on the pot. The portion of the pot rising above the stove is approximately 25% of the height of the pot.

Note 2

The mortar thickness between the curved bricks is assumed to be 10 mm. Only Fire Cement (fire clay mortar) should be used with bricks exposed to high temperature which includes the firebox, the fuel shelf and all the curved bricks.

Do not use Ordinary Portland Cement (OPC) mixed with "grog" as that mix is not fireproof. OPC burns away at 400°C .

To achieve a good bond, each brick should be dipped in water before being buttered and pressed into place. The Fire Cement should be wet enough so each brick can be vibrated by hand to achieve a solid, wet bond with 10 mm thickness.

Using the pot as a form, make a small 40 mm thick spacer to set the distance from the pot to the curved brick.

Layers 8-12

2024 MEMD 250 LITRE STOVE

Key Features:

Primary air is supplied between the bricks under the fuel

Bricks block direct exit of gases

Brick combustion chamber

Material: Brick and High temperature brick

Quantity: Various

Scale: Not to scale

Version: Date: Initials CPP

Drawn By: C Pemberton-Pigott

Drawing No. 14 MEMD 250 Litres - Layers 8-12

Part Bricks: Layers 8-12